

(19)



(11)

EP 1 755 431 B1

(12)

EUROPEAN PATENT SPECIFICATION

(45) Date of publication and mention of the grant of the patent:
17.07.2013 Bulletin 2013/29

(51) Int Cl.:
A47L 5/38 (2006.01) A47L 9/28 (2006.01)

(21) Application number: **05745156.9**

(86) International application number:
PCT/CA2005/000715

(22) Date of filing: **11.05.2005**

(87) International publication number:
WO 2005/107554 (17.11.2005 Gazette 2005/46)

(54) **CENTRAL VACUUM CLEANING SYSTEM CONTROL SUBSYSTEMS**

ZENTRALE STAUBSAUGSYSTEMSTEUERUNTERSYSTEME

SOUS-SYSTEME DE COMMANDE D'UN SYSTEME CENTRAL DE NETTOYAGE PAR ASPIRATION

(84) Designated Contracting States:
AT BE BG CH CY CZ DE DK EE ES FI FR GB GR HU IE IS IT LI LT LU MC NL PL PT RO SE SI SK TR

(72) Inventor: **CUNNINGHAM, J. Vern**
Aurora, ON M4P 1V2 (CA)

(30) Priority: **12.05.2004 US 843321**
09.09.2004 US 936699

(74) Representative: **Schüssler, Andrea et al**
Kanzlei Huber & Schüssler
Truderinger Strasse 246
81825 München (DE)

(43) Date of publication of application:
28.02.2007 Bulletin 2007/09

(56) References cited:
JP-A- 8 065 876 JP-A- 8 117 165
JP-A- 10 094 504 JP-A- 2002 078 656
JP-A- 2003 235 767 US-A- 3 626 545
US-A- 5 274 878 US-A- 5 343 590
US-A1- 2002 152 576

(73) Proprietor: **Cube Investments Limited**
Aurora ON L4G 3V7 (CA)

EP 1 755 431 B1

Note: Within nine months of the publication of the mention of the grant of the European patent in the European Patent Bulletin, any person may give notice to the European Patent Office of opposition to that patent, in accordance with the Implementing Regulations. Notice of opposition shall not be deemed to have been filed until the opposition fee has been paid. (Art. 99(1) European Patent Convention).

Description

TECHNICAL FIELD

[0001] The invention relates to central vacuum cleaning systems. More particularly, it relates to control subsystems for central vacuum cleaning systems.

BACKGROUND ART

[0002] Many modern buildings have central vacuum cleaning systems. These systems have a suction motor to create a vacuum in a series of pipes through the building. A user of the system connects a flexible hose to one of the pipes. The hose has a handle for the user to grasp. The handle is further connected to one or more cleaning accessories.

[0003] The motor is housed in a motor housing that typically forms part of a central vacuum unit, often referred to as a "canister". The canister also has a receptacle portion for receiving dust and other particles picked up through the cleaning accessories and transported by the vacuum through the hose and pipes.

[0004] The canister is usually placed in a central location that is easily accessible for emptying the receptacle. The motor is typically powered by line voltage that is controlled by a motor control circuit in the motor housing.

[0005] Low voltage wires typically run beside, or form part of, the pipes and hose between the canister and the handle. This permits the user to control the motor by sending low voltage signals from the handle to the motor control circuit. In order to receive the low voltage signals, an opening is provided in the motor housing through which the low voltage wires can be connected to the motor control circuit.

[0006] Installation of the low voltage wires can involve a great deal of effort, particularly when the system is being installed in an existing building. It is known to use a hand held radio frequency remote control to control a central vacuum unit. It is known to transmit control signals through existing power lines in a building. Add-on remote control units for turning on and off a central vacuum unit are also known.

[0007] JP8117165(A) and JP2003/235767(A) each disclose portable vacuum units having over-current protection".

[0008] Improvements to, or alternatives for, existing central vacuum cleaning systems and central vacuum cleaning system control subsystems are desirable.

DISCLOSURE OF THE INVENTION

[0009] The present disclosure provides a central vacuum cleaning system control subsystem according to claim 1.

[0010] The present disclosure also provide a method of controlling a central vacuum cleaning system suction motor according to claim 21.

BRIEF DESCRIPTION OF THE DRAWINGS

[0011] For a better understanding of the present invention and to show more clearly how it may be carried into effect, reference will now be made, by way of example, to the accompanying drawings that show the preferred embodiment of the present invention and in which:

FIG. 1 is a schematic diagram of a central vacuum cleaning system control subsystem in accordance with the preferred embodiment of the present invention;

FIG. 2 is a side view of a central vacuum cleaning system hose handle for use with the subsystem of FIG. 1;

FIG. 3 is a side view of an alternate central vacuum cleaning system hose handle for use with the subsystem of FIG. 1;

FIG. 4 is a plan view of the handle of FIG 3;

FIG. 5 is a schematic diagram of a power stage for use in the subsystem of FIG. 1;

FIG. 6 is a schematic diagram of an alternate power stage for use in the subsystem of FIG. 1;

FIG. 7 is a block diagram of a central transmitter submodule for use in the subsystem of FIG. 1;

FIG. 8 is a block diagram of a central receive submodule for use in the subsystem of FIG. 1;

FIG. 9 is a block diagram of a central transceiver submodule for use in the subsystem of FIG. 1;

FIG. 10 is a block diagram of a central timer submodule for use in the subsystem of FIG. 1;

FIG. 11 is a block diagram of a central operating condition submodule for use in the subsystem of FIG. 1;

FIG. 12 is a block diagram of a central operating condition sensors for use in the central operating condition submodule of FIG. 11;

FIG. 13 is a block diagram of a remote transceiver submodule for use in the subsystem of FIG. 1;

FIG. 14 is a detailed block diagram of a central control submodule for use in the subsystem of FIG. 1;

FIG. 15 is a side cross-section of a building incorporating a central vacuum cleaning system using an embodiment of the subsystem of FIG. 1;

FIG. 16 is a cut-away perspective view of a vacuum source for use in the cleaning system of FIG. 15 incorporating an embodiment of the subsystem of FIG. 15;

FIG. 17 is a cross-section of a hose handle utilizing a battery charging device in accordance with an embodiment of the present invention;

FIG. 18 is a cut-away partial perspective view of an alternate vacuum source for use in the cleaning system of FIG. 15 incorporating an embodiment of the subsystem of FIG. 15;

FIG. 19 is a cut-away partial perspective view of an alternate vacuum source for use in the cleaning system of FIG. 15 incorporating an embodiment of the subsystem of FIG. 15, including an air powered generator; and

FIG. 20 is a perspective of a portion of a building incorporating a remote station in accordance with an embodiment of the present invention.

MODE(S) FOR CARRYING OUT THE INVENTION

[0012] Referring to FIG. 1, a central vacuum cleaning system control subsystem 1 has a central control module 3 and a remote control module 5.

[0013] The central control module 3 controls power from a power source 7 to a motor 9, and by doing so the central control module 3 controls the operation of the motor 9. The power source 7 is typically line voltage, for example, 120V or 240V, 60Hz AC in North America or 230V, 50 Hz AC in Europe.

[0014] The remote control module 5 is connected to a user input/output interface 13. The remote control module 5 receives input from a user 11 through the interface 13. User input may be as simple as a request for a change of state of the motor 9 where the interface 13 would be a toggle switch 13.

[0015] The remote control module 5 is a wireless transmitter. It encodes the input received from the user for wireless transmission to the central control module 3 as indicated by the arcs 15. The central control module 3 is a wireless receiver. It receives the wireless transmission from the remote control module 5, decodes it and controls the motor 9 accordingly. For example, if the user requests the motor 9 to change state then if the central control module 3 is providing power from the source 7 to the motor 9 then the central control module 3 will cease doing so. If the central control module 3 is not providing power from the source 7 to the motor 9 then it will provide power.

[0016] The central control module 3 is also a wireless transmitter. The central control module 3 senses the operating condition of the motor 9, encodes a message related to the condition and wirelessly transmits the message to the remote control module 5 as indicated by the

arcs 17. The message is received by the remote control module 5, decoded, and provided to the user 11 through the interface 13.

[0017] Referring to FIG. 2, a hose handle 20 incorporates the interface 13 as a display means 21 and switch 23. A toggle switch 23 is shown in the FIGS.; however, various types of switches, such as for example a momentary switch, not shown, could be used. The display means 21 may take the form of one or more lights, such as LEDs and/or an LCD screen with icons. Alternatively, or in addition, the display means may have a speaker or buzzer to provide sound output to the user by way of voice or an alarm. A transducer may be used to create sounds. This provides bi-directional communication between the central control module 3 and the remote control module 5, and thereby provides bi-directional communication between the user 11 and the motor 9 as will be discussed further herein.

[0018] In a preferred embodiment, the central control module 3 is able to provide more complex control of the motor 9 beyond simply turning it on and off. For example, the central control module 3 may be able to adjust the speed at which the motor 9 operates. There are many different techniques for adjusting motor 9 speed, some of which are dependent on the type of motor 9.

[0019] For example, existing central vacuum cleaning systems typically use a universal motor 9. The speed of a universal motor 9 can be controlled by reducing the voltage applied to the motor 9. DC motors 9 have also been described for use as vacuum motors 9, see for example, WO03075733A1. The speed of a DC motor 9 can be adjusted by adjusting the voltage for a series wound motor 9, or by controlling the excitation on the armature of a shunt wound motor 9.

[0020] Where the central control module 3 has the ability to control motor 9 speed then it may be desirable to provide for a "soft start". This can be done by starting the motor 9 at a slower desired speed and working up to a higher speed. This can increase the longevity of the motor 9, particularly for universal motors 9 where starting can result in a high inrush current that has a cumulative detrimental effect on motor 9 windings over time. Soft start control can be configured as an internal setting of the central control module 3 without requiring external user input.

[0021] The user 11 can be permitted to adjust the speed of the motor 9 on demand by requesting such an adjustment through the user input/output interface 13. This can be done by providing additional user inputs at the interface 13, for example more switches 25, 27, or it may be more effectively done by interpreting the signals from the user 11 through a lesser number of inputs, for example switch 23 only. For example, the switch 23 can be actuated to signal a particular request. A series of switch 23 actuations may signal a request for a decrease motor 9 speed another series of switch 23 actuations may signal a request for an increase in motor 9 speed. Another signal would indicate on and another off.

[0022] An easier interface 13 for the user 11 would include two switches 23, 25. Repeated actuation of one switch 23 signals a request for an increase in speed, while repeated actuation of the other switch 25 signals a request for a decrease in speed. A single actuation of one switch 23 could indicate a request to turn the motor 9 on, while a single actuation of the other switch 25 could indicate a request to turn the motor 9 off. For example, each request for a decrease in speed could result in a 10% reduction to a maximum of a 50% reduction. Rather than incrementally increasing speed, the user could be required to request the motor 9 to be turned off and then on through the interface 13. This could reset the speed to 100%.

[0023] More switches or input devices, not shown, could be added as desired. Referring to FIGS. 3 and 4, an alternative interface 13 might be a touch screen 30 that could incorporate both a display and input device. The touch screen could display various icons or text representing messages from the central control module 3 regarding the operating condition of the motor 9. Icons or text could also be provided to allow the user 11 to send messages to the central control module 3 by touching the icons or text.

[0024] Many power stages can be used to decrease (and to increase) the voltage to the motor 9. Referring to FIG 5, the preferred embodiment of a power stage 38 (shown in dashed lines) is to use a solid-state controller, such as a triac 40. A triac 40 can be easily controlled using other solid-state components such as, for example, a microprocessor or a microcontroller, not shown in FIG. 5, but an example will be later described. The triac 40 can be driven by a gate signal 42 (for example, from the microprocessor or microcontroller) that is phase shifted depending on the effective voltage desired. This is known as a phase-angle drive. At a minimum it requires only a gate driving signal 42 and a single additional component: the triac 40.

[0025] In this description the term "solid-state" will be used to describe components that have no moving parts. Solid-state components can be integrated circuits, such as microprocessor, or discrete components such as a single capacitor or resistor.

[0026] Referring to FIG. 6, a more complex power stage 50 (shown in dashed lines) may be used to control the voltage from voltage source inputs 52 seen by the motor 9 using, for example, an input rectifier 54, a power switch (transistor) 56 and a diode 58. This uses a Pulse Width Modulation gate drive signal 59 to adjust the effective voltage seen by the motor 9 to be varied. This is known as a chopper drive. It is still a solid-state device without mechanical components, such as those mechanical components that are used in some relays and circuit breakers that are typically found in existing central vacuum units.

[0027] The central control module 3 also has a number of submodules that operate based on a variety of sensed conditions. Referring to FIG. 7, central transmit submod-

ule 60 has a transmit (Tx) subcontrol 61, a wireless transmitter 62 and an antenna 64. The Tx subcontrol 61 encodes messages to be transmitted wirelessly by transmitter 62 through the antenna 64.

[0028] Referring to FIG. 8, a central receive submodule 66 has a receiver (Rx) subcontrol 67, wireless receiver 68 and an antenna 70. The Rx subcontrol 67 decodes messages received by the receiver 68 through the antenna 70. The antenna 64 and 70 may be one in the same component if desired, and designed for, by the designer in a manner that would be evident to those skilled in the art.

[0029] Referring to FIG. 9, the central transmit submodule 60 and central receive submodule 66 may be replaced by a central transceiver submodule 72 having a transmit/receive (Tx/Rx) subcontrol 74, a transceiver 76 and an antenna 78. The submodule 72 encodes and decodes, transmits and receives messages through antenna 78 in a manner similar to the central transmit submodule 60 and the central receive submodule 66, combined.

[0030] The wireless transceiver 76 combines a transmitter and receiver in a single component. Among other benefits, the use of an integrated transceiver 76 can reduce complexity, power consumption and size. Also, transceiver for unlicensed short distance communication typically utilize higher frequencies for less interference and more effective communication.

[0031] This description will be made primarily with reference to a central transceiver submodule, such as submodule 72. It is to be understood that discrete transmit submodules, such as submodule 60, and discrete receive submodules, such as submodule 66, could be used as necessary for a particular application, if desired.

[0032] Referring to FIG. 10, the central control module 3 has a timer submodule 80 with a timer 82, a timer subcontrol 84 and a power stage 86. The timer 82 commences timing on the instruction of the subcontrol 84 when the power stage 86 powers on the motor 9. If the timer 82 times more than a predetermined amount of time then the timer subcontrol 84 instructs the power stage 86 to stop providing power to the motor 9. For example, if the motor 9 has been running for 30 minutes then the timer submodule 80 shuts off the motor 9. This safeguards against inadvertent operation of the motor 9. If a user 11 wishes to continue use then the user 11 simply activates the motor 9 through the interface 13, and the timer submodule 80 starts timing again.

[0033] The timer submodule 80 is also connected to the central transceiver submodule 72 for transmission of messages to the remote control module 5.

[0034] Referring to FIG. 11, the central control module 3 has an operating condition submodule 90 with one or more operating condition sensors 92, an operating condition subcontrol 94 and a power stage 96. The operating condition sensors 92 sense various operating conditions of the motor 9 under the control of the operating condition subcontrol 94. According to the sensed operating condi-

tions, the operating condition subcontrol 94 controls the power stage 96 by, for example, providing gate drive signals. The operating condition submodule 90 is also connected to the central transceiver submodule 72 for transmission of messages to the remote control module 5.

[0035] Thus, the central control module 3 senses an operating condition of the motor 9, compares it to a normal operating condition of the motor 9 (examples of which will be described), determines if the motor 9 is operating significantly outside a normal operating condition, and performs an action if the motor 9 is operating outside the normal operating condition. Examples of various sensors will be described herein; also, an example microprocessor embodiment for comparing, determining and performing will be described. An example of a performer for performing an action is the subcontrol 94 described above that controls the power stage 96 after determination. In this case, the subcontrol 94 carries out the comparison and determination, and performs the action. Other example performances of actions will be described herein.

[0036] Referring to FIG. 12, one of the operating condition sensors 92 may be a current sensor 98 for sensing the motor 9 operating current. If there is an overcurrent condition then the central control module 3 will disconnect power from the motor 9 by having the operating condition subcontrol 94 instruct the power stage to stop providing power 96 to the motor 9. Overcurrent might be determined by a current that is more than a given amount above the normal operating current of the motor 9. In the preferred embodiment an overcurrent condition is a current of more than 100% above (twice) the normal operating current where such current is present for over 3 seconds. Such a condition is indicative of something jammed in an impeller or other suction creating device, not shown, attached to the motor 9, and the motor 9 is working to overcome the obstruction. The actual thresholds used will depend on the particular specifications for the motor 9 used in any particular application. After an overcurrent condition occurs, it is best to require disconnection of a source of power from the central control module 3 before the motor 9 can be restarted. This is a safety feature. An overcurrent condition can require maintenance. If it occurs repeatedly then the user will likely make a call for service rather than repeatedly disconnect and re-connect the power source.

[0037] Referring to FIG. 11, in order to provide specifications on which a threshold can be based the central control module 3 can have a non-volatile memory 102 in which the specifications can be stored. The specifications can be sensed during normal operating condition of the motor 9 and stored. Such condition may be represented by the current drawn by the motor 9. This can easily be sensed by the operating condition sensor 92 under control of the operating condition subcontrol 94.

[0038] The normal operating condition of the motor 9 could also be input directly by the user 11 at the interface 13 and transmitted from the remote control module 5 for

reception at the transceiver 72, decoding by the transceiver subcontrol 74 and storage in memory 102. The memory 102 is a rewriteable device such as, for example, an EEPROM, EPROM or flash memory device. Alternatively, the normal operating condition can be pre-configured in memory 102 by an installer, or at the time of manufacture. If the normal operating conditions are input at the time of manufacture or installation then a write once memory device, such as a PROM, could be used, if desired.

[0039] As the central control module 3 may be used with many different motors 9, and the design specifications and operating environment of each motor 9 may change from time to time, it is preferable simply to allow the central control module 3 to sense automatically (i.e. without requiring data to be input by a user 11, manufacturer or installer) the normal operating condition when the central control module 3 is installed.

[0040] The central control module 3 will need to be configured to ignore any inrush current each time the motor 9 is turned on if the inrush current would exceed the threshold amount and duration. A soft-start configuration as described previously can be used to reduce inrush current. The soft start can be implemented through motor 9 control using, for example, one of the power stages 38, 50.

[0041] The current sensor 98 may be a current sensing transformer, current sensing resistor or other similar or alternative device in line with, or integrated into, the power stage (for example, 38, 50) or elsewhere in the central control module 3.

[0042] The central control module 3 operating condition submodule 90 can also sense an undercurrent condition of the motor 9. This typically signifies a blockage in an air inlet to the motor 9. Such a blockage stops air flow, resulting in free spinning of the motor 9 and a reduction in load on the motor 9. If this condition persists for longer than a predetermined period then the central control module 3 can automatically disconnect power to the motor 9. Also or alternatively, notice could be provided to the user 11. As an example, the predetermined period could be set for approximately 15 minutes. The period should be long enough to allow the user to remove typical blockages, while not so long as to continue operation on an ongoing basis in an underperforming condition.

[0043] Referring again to FIG. 12, the operating condition sensors 92 may also include a temperature sensor 104 that monitors the temperature around the motor 9. An over temperature condition can be detected in comparison to normal operating temperature stored in memory 102. The central control module 3 under control of the operating condition submodule 90 ceases to provide power to the motor 9 when an over temperature condition occurs. To again use the motor 9, a source of power to the vacuum source 205 of FIGS. 15 and 16 must be disconnected (for example by unplugging the power to the vacuum source 205) from the central control module 3

by the user 11, and reconnected. Additionally, the over-temperature condition must have cleared. Again, this is a safety feature. Repeated overtemperature conditions may indicate that maintenance is required.

[0044] The memory 102 may also store the normal operating temperature (or other representation on which a threshold may be based) input, for example, in the manner described for the normal operating current, except possibly using the temperature sensor 104 to sense normal operating temperature.

[0045] An accelerometer or other vibration or motion sensor 106 can be incorporated into the central control module 3 to sense for vibration. Unusual ongoing vibrations can be an indication that the balance of the motor 9 is off, and the motor 9 may be starting to fail. The normal and current conditions can be sensed with the normal condition being stored in memory 102 for future comparison.

[0046] The central control module 3 can be used in association with an autodialer to provide information about the cleaning system to a remote location through telephone lines. Contact could be made as a result of a sensed condition or the passage of time. The central control module 3 could also receive a remote call for diagnostic purposes. Referring to FIG. 13, remote control module 5 incorporates a remote transceiver submodule 110 similar to that of the central transceiver submodule 72, including a remote transceiver 112, remote transceiver subcontrol 114, and antenna 116. The operation of the remote transceiver submodule 110 and central transceiver submodule 72 are similar and will not be repeated. It is to be noted that the functions of the remote transceiver submodule 110 could be replaced by a separate transmitter submodule and/or receiver submodule, not shown.

[0047] In the preferred embodiment, the transceiver submodules 72, 110 of central control module 3 and remote control module 5, respectively, are matched for transmission and reception of signals over a distance of approximately 150 ft. through typical residential obstacles and building materials. The design distance is a matter of choice, governed by applicable legal requirements such as might apply to signal strength and frequency. A digitally modulated radio frequency (r.f.) carrier of 433.92 MHz is suitable as it meets current North American and European requirements for r.f. control systems.

[0048] Alternatively, r.f. transmissions can operate in spread-spectrum mode. This could include frequency hopping spread spectrum or direct-sequence spread spectrum (DSS). These techniques enable operation at higher r.f. power levels than single frequency operation by distributing the power over a number of different frequency channels. In this case, the carrier frequency could be in the 850-950 MHz or 2.4 GHz bands to comply with legal requirements in North America and Europe. In this case, design for a minimum distance of approximately 300 ft. between central control module 3 and remote control module 5 is preferred.

[0049] Other r.f. transmission techniques and frequencies could be used as desired for particular applications.

[0050] A microprocessor can be used as the transceiver subcontrol 114 in the remote control module 5 to provide the digital encoding of r.f. carrier with message data, and to decode messages received from the central control module 3. Other devices such as a microcontroller or discrete components could be used to perform these functions.

[0051] Wireless communication provides a significant advantage. Wired low voltage signals require a step down transformer from line voltage to low voltage, such as a class II safety transformer. Wireless communication obviates the need for low voltage signals and the class II transformer for that purpose.

[0052] The central control module 3 can be powered using a drop down resistor or capacitor from the power source 9. A non-class II transformer can be used in the event that larger power is required as wireless communication does not require the use of a class II transformer. It may still be desired to use a class II transformer in order to allow a manufacturer to provide an option to communicate via low voltage wires connected between the central control module 3 and the remote control module 5. The selection between wired and wireless communication can be made at the time of manufacture, or the manufacturer can leave this selection up to the installer. If the selection is made by the manufacturer then separate different central control modules and remote control modules can be made for wired and wireless configurations.

[0053] It is to be understood that wireless communication is not required for all of the functions described herein. In fact, for many functions it is not necessary to have communication between the user 11 and the central vacuum source 205, except to turn the motor 9 on and off. The other functions can operate without user intervention; however, this is not the preferred embodiment.

[0054] In order to meet regulatory requirements a circuit breaker is typically used to limit current. The circuit breaker uses a bimetallic strip. The bimetallic strip is sensitive to ambient temperature and results in nuisance tripping of the circuit breaker when operated in high ambient temperatures. By using a current sensing resistor or transformer as the current sensor 98 to sense an overcurrent condition, a microprocessor can be used as the operating condition subcontrol 94 to turn off a triac in a power stage, or activate a relay in a power stage, to control current to the motor 9 to shutdown the motor 9. This protects the motor 9. In some cases, a triac can fail in such a way that current would not be shut off to the motor 9. It may be preferable to include a redundant overcurrent protection device for otherwise catastrophic failure, such as a trace on a printed circuit board for the central control module 3 of a size to act as a fuse on the load (motor 9) side, opening in the event of a sustained overcurrent condition and preventing current from flowing to the motor 9. Other redundant overcurrent protection devices could be used.

[0055] Referring to FIG. 14, the various submodules of the central control module 3 can be combined. In combining the submodules, the various subcontrols can also be combined into a single central control subcontrol 160 which can utilize a single microprocessor, microcontroller or combination of discrete components, to perform the functions described herein for each of the submodules. The memory 102 can be part of the microprocessor or microcontroller, or it may itself be a discrete component. Preferably, the central control subcontrol is a microprocessor with integrated memory 102. The entire timer submodule may be part of the microprocessor, or it may be a combination of the microprocessor and a few discrete components to set the proper timing for the timer. Alternatively, the timer may comprise components discrete from the microprocessor.

[0056] The various subcontrols, microprocessor and microcontroller are programmed to perform the functions described herein. The programs are contained in a non-volatile memory, such as memory 102, or an internal memory within the subcontrol, microprocessor or microcontroller.

[0057] Referring to FIG. 15, a central vacuum cleaning system (indicated generally at 201) incorporates a control subsystem 1 in the form of central control module 3 and remote control module 5 as will be further described. The system 201 is installed in a building 203. The building 203 is shown as a residence; however, the system 201 could be installed in other buildings, such as commercial or industrial buildings.

[0058] The system 201 has a vacuum source 205 in a central location. The source 205 is connected through pipes 207 or other conduits in walls, floors or ceilings of the building 203. Alternatively, the pipes 207 may be exposed. The pipes 207 terminate at valves 209 to which a flexible hose 211 may be connected. The hose 211 terminates in a handle 213 that is held by a user 11. Various cleaning attachments, such as a carpet brush 216, are connected to the handle 213.

[0059] Control signals, such as ON/OFF, from the user 11 are provided through a switch 218 (or switches 218 or some other interface 13 in the handle 213. More sophisticated systems 201 may utilize the control signals for many other purposes, such as duplex communications that allow the receipt of information at the handle 213. Such information could be used to drive LEDs or other display means 219 (as described previously for the interface 13) for communication with the user 11. When the user 11 turns on the system 201, dirt is drawn by a vacuum created by the vacuum source 205 through the attachment 216, handle 213, hose 211, and pipes 207.

[0060] Referring to FIG. 16, the vacuum source 205 has a motor 9 (FIG. 1) within a motor housing 221. Extending from the motor housing 221 is, typically, a receptacle 223 for receiving the dirt. Also within the motor housing 221 is a motor control circuit 225 embodying central control module 3 of FIG. 1. In the preferred embodiment, the motor housing 221 also acts as a motor control hous-

ing 221. Accordingly, the motor housing 221 will be referred to as a motor control housing herein, unless the context requires otherwise. It is to be understood that the motor housing and motor control housing could be separate from one another.

[0061] Preferably, the central control module 3 (including its transceiver 74) is placed within the motor control housing 221. Alternatively, the central control module 3 could be distributed with the transceiver 74 portion outside the motor housing 221 to avoid interference and signal attenuation.

[0062] The motor control circuit 225 is typically laid out on a printed circuit board 233, including all of the components to implement the functions of the central control module 3. Multiple printed circuit boards or separately mounted components may be used as desired.

[0063] The motor control circuit 225 can be mounted in many different ways, for example on mounting screws or posts, not shown, inside or outside the motor control housing 221. It may be preferable to mount the motor control circuit 225 in the cooling air inlet passage or outtake (exhaust) of the motor 9 to provide cooling for the circuit 225. Any power stage of the circuit 225, in particular, may benefit from such cooling.

[0064] Although the preferred embodiment is being described with reference to a motor control circuit 225 for mounting inside a motor housing 221, as mentioned previously, the circuit 225 need not be mounted inside the motor housing 221. For example, the circuit 225 could be mounted within a control box, not shown, outside the housing 221 with wires fed back into the housing 221 for operation of the motor 9. This might be done for additional isolation of the control circuit 225 from the motor 9. For example, it might be helpful to avoid electromagnetic interference from the motor 9. The control box would be an alternate form of motor control housing 221. As mentioned previously, for this reason, the motor housing 221 is being referred to as a motor control housing 221 in this description, unless the context requires otherwise.

[0065] In the preferred embodiment, the central control module 3 also has means for communication with the user 11. In the preferred embodiment, means for communication with the user 11 takes the form of an LED, not shown, within a translucent mounting post 227. The motor control circuit 225 has optional wired and wireless communication paths. Accordingly, the pointing post accepts connections from low voltage wires. As an alternative display example, the LED could extend through the housing 221 for direct viewing.

[0066] LEDs are a preferred choice as LEDs are long lasting, small, inexpensive, and low power devices. Higher power LEDs, LEDs of different colours, multi-colour LEDs, and LEDs of different shapes and sizes may all be used. Standard LED packages such as a T-1 or T-1½ can be used. These tend to be the least expensive. This allows for LEDs of more than 3000 mcd, for example 3200 mcd and 4500 mcd in green. These are examples only and many other sizes and configurations can be

used. For example, a multi-colour LED could be used to provide many possible signalling combinations, such as a red/yellow LED that can provide red solid, red flashing, yellow solid, yellow flashing, orange solid, and orange flashing. Also, single colour LEDs can be chosen from a wide variety of colours, including green, yellow, red, white and blue, among others.

[0067] The messages provided to the user 11 by the LEDs might include, for example, 1) informing the user that electrical power is present and the system 1 has no apparent problems (LED GREEN), 2) air flow is obstructed, check for obstructions, including in the pipes 207, in the flexible hose 211 or the filter medium, or the dust receptacle 223 is full and should be emptied (LED YELLOW), 3) a sensor indicates that service to the system 201 is needed, for example, an overcurrent condition shutdown that may indicate a problem such as bearing failure (LED flashes RED), and 4) a certain amount of time has passed indicating that service to the system 201 is needed, for example: service to the motor is required, i.e. change the brushes (LED flashes YELLOW). These are samples of the types of messages that might be conveyed to the user. Many other messages could be conveyed as desired by designers of motor control circuit 225 using other colours or flashing patterns.

[0068] Referring to FIG. 17, in a manner similar to that described for the central control module 3, the remote control module 5 is mounted in a handle, for example handle 29, typically on a printed circuit board 240. It is to be noted that other handles, such as for example handles 20, 213 could be used. The printed circuit board 240 and other components of the central control module 3 could be fully encapsulated with simply a couple of wires 242 extending for connection to a power source 244. Messages are provided to the user 11 in the manner described previously herein. The messages provided to the user 11 include, for example, those previously described for the central control module 3.

[0069] The remote control module 5 is preferably battery 244 powered; however, it may also be powered from line voltage where it is available, using a drop down resistor and capacitor. Many vacuum hoses 217 have line voltage as it is used to power hose attachments 216, such as a power carpet brush. The battery 244 could be a rechargeable battery 244. Batteries 244 provide energy for limited durations. This duration for a rechargeable battery 244 is typically far shorter than that for a non-rechargeable battery 244. In order to avoid having to frequently change the battery 244, the battery 244 could be a rechargeable battery 244 that is recharged by using a generator 246 powered from vacuum air (arrows 247) flowing through the handle 29 to produce electrical energy. The generator could be powered by an impeller 249 that extends into vacuum air path 248. The impeller 249 would turn, causing the generator 246 to produce current for recharging the battery 244. The generator 246 would typically produce alternating current that would require an AC/DC converter and/or other battery charging cir-

cuitry 250 for charging the battery 244. The voltage may need to be stepped-up in order to provide sufficient voltage for charging the battery 244. Many designs for such converters, including step-up converters, are readily available and could be used for this purpose.

[0070] To avoid damage to the impeller 249 from passing dust particles, a separate impeller air path 252 can be provided for the impeller 249. The impeller air path 252 extends from the vacuum air path 248 through the handle 29 to allow ambient air 254 to be drawn in through the impeller air path 252 to the vacuum air path 248. The motion of the ambient air 254 flowing through impeller air path 252 causes the impeller 249 to turn. The motion of the impeller 249 then powers the generator 246. As an example, the impeller air path 252 could be a one-quarter inch hole. It is desirable to have a wide input power range, for example, 90-260 volts AC for worldwide use. The use of a 16 Amp 400 Volt triac in the central control module 3 will work with most commercially available motors used in residential central vacuum cleaning applications worldwide. If a relay is used to control the motor 9 then a different relay will likely be required for different voltages, amperages and regulatory requirements. The drop down circuits for powering the central control module 3 are preferably adapted to utilize this wide range of voltages as well using well known power conversion techniques. As described previously, for universal use with motors 9 having different, and perhaps unknown specifications, the central control module 3 can sense normal operating conditions and store them in memory. This process can be thought of as a learn mode for the control subsystem 1. During initial operation of the central control module 3, the module can sense the operating conditions of the motor 9. These can be stored in non-volatile memory 102 for the microprocessor 160. The stored operating conditions can then be used for a baseline against which the central control module 3 can compare when in use. In addition to motor 9 normal operating current, the stored conditions may include, for example, such conditions as vacuum pressure and ambient temperature. Ambient temperature varies from building to building, and this may affect what is considered to be "overtemperature". Vacuum pressure may be sensed in many different ways, for example, surface mount pressure sensors are becoming widely available.

[0071] Referring to FIG. 18, low voltage electrical components, such as central control module 3, could be similarly powered by a rechargeable battery 260 charged from a generator 262 having an impeller 264 placed in an exhaust air path 266 in central vacuum canister 268. The impeller 264 turns with the motion of air 270 flowing through the central cleaning system, for example, in the canister 268 from an inlet 272 to an outlet 274 over bag 275. Air flow is generated by suction motor 276. It is desirable, although not necessary, to place the impeller in the exhaust air path 266 as the air is typically filtered of dust particles 277 by a filter 278 after dust separator 280 and prior to motor 276. The filter reduces wear on the

motor 276. Similarly, it reduces wear on the impeller 264.

[0072] Referring to FIG. 19, for flexibility, for example in retrofit applications or as optional features, the central control module 3 and ancillary components, including battery 260 and generator 262, could be placed outside the canister 268. The impeller 264 could form part of a pipe insert 282 inserted after outlet 274 in the exhaust air piping 284. The insert 282 allows exhaust air to flow through, while placing the impeller 264 in the exhaust air path 270.

[0073] Optionally, the central control module 3 could connect to existing low voltage connectors 286 on the canister 268 to provide signals to an existing control unit 288 controlling the motor 276. Controlling motor 276 through an existing control unit 288 may limit available features and functions of the central control unit 3. Advantageously, for retrofit applications, the central control unit 3 would not require access to line voltage; however, the central control unit may not have access to the input current of the motor 276, preventing use of features related thereto.

[0074] Low voltage units that do not connect to line voltage would not require certification in most jurisdictions, or such requirements would be less strict.

[0075] It is to be noted that the use of a generator powered by air flowing through a cleaning system is not limited to central vacuum cleaning systems. For example, portable upright or canister vacuum cleaners may benefit from a generator powered by air flow for driving electrical devices within the cleaner. This may include a remote control module and central control module, such as those described herein that communicate between a handle and motor of the cleaner.

[0076] Referring to FIG. 20, a remote station 280 having a display 282, such as an LCD screen with or without touch screen functions, could be placed within a building 290 to receive status information for the cleaning system 201. The remote station 280 could be mounted to a wall or elsewhere within the building 290, or it could be portable. The remote station 280 could communicate wirelessly with the motor control 3 in the same manner as the remote control module 5 in the handle 213. The remote station 280 may allow for two-way communication and, in this way, the remote station 280 can duplicate, replace or augment some or all of the functions of the remote control module 5. The screen of the remote station 280 could be larger than that of the remote control module 5.

[0077] The remote station 280 could also access other automated functions in the building 290. In this way, the need for multiple remote control screens in a building 290 could be reduced. Communication between the remote station 280 and the central control module 3 can be through an intermediary transceiver, such as an x 10 control module adapted to wirelessly receive signals from and transmit signals to the central control module 3 and to correspondingly transmit signals to the remote station 280 and receive signals from the remote station 280.

[0078] The transmission to and reception from the remote station 280 by the intermediary transceiver may be wireless or wired. For example, power line communication could be used, or network cabling. The remote station 280 could be a personal or other computer, or a dedicated device, such as an x 10 compatible control panel.

Claims

1. A central vacuum cleaning system control subsystem (1) for use in a central vacuum cleaning system having a suction motor (9), the subsystem comprising a central vacuum source control module (3) for controlling a central vacuum cleaning system suction motor, the module comprising:

a) at least one sensor (92), with each sensor sensing a respective operating condition of the motor (9), a current sensor of the at least one sensor for sensing motor current of the motor (9);

b) at least one comparator (94) with each comparator (94) comparing each sensed operating condition of the at least one sensed operating condition to a corresponding normal operating condition for that sensed operating condition of the motor (9) and for determining when the motor (9) is operating significantly outside at least one corresponding normal operating condition for the motor (9) for a given period of time; and
c) a performer (94) for, when the comparator determines that the motor is operating significantly outside the normal operating condition for the motor current, performing at least one action, the action comprising transmitting a message to a remote module (5) to generate a user alert at the remote module.

2. The subsystem of claim 1, wherein the performer (94) shuts down the motor (9) when the comparator (94) determines that the motor current is operating significantly outside the normal operating condition for the motor current.

3. The subsystem of claim 1, wherein the performer (94) ceases to provide current to the motor when the comparator determines that the motor (9) is operating significantly outside the normal operating condition for the motor current.

4. The subsystem of claim 1, wherein the performer (94) ceases to provide current to the motor (9) when the comparator determines that the motor is operating significantly outside the normal operating condition for the motor current such that the motor current is in an overcurrent condition.

5. The subsystem of claim 1, wherein the performer (94) provides a user alert when the comparator (94) determines that the motor is operating significantly outside the normal operating condition for the motor current such that the motor current is in an overcurrent condition. 5
6. The subsystem of claim 1, wherein: the performer comprises a radio frequency wireless transmitter and the performer (94) transmits a radio frequency wireless message when the comparator determines that the motor (9) is operating significantly outside the normal operating condition for the motor current. 10
7. The subsystem of claim 1, wherein the at least one sensor is a plurality of sensors comprising the current sensor (98) and a temperature sensor (104) for sensing temperature around the motor (9). 15
8. The subsystem of claim 1, wherein the at least one sensor is a plurality of sensors comprising the current sensor (98) and a vibration sensor (106) for sensing vibrations. 20
9. The subsystem of claim 1, wherein the at least one comparator comprises a microcontroller for comparing a respective one of the at least one sensed operating conditions to a corresponding normal operating condition for that sensed operating condition of the motor (9) and for determining when the motor (9) is operating significantly outside the corresponding normal operating condition for the motor for a given period of time. 25
10. The subsystem of claim 1, wherein the at least one comparator (94) comprises a microcontroller for comparing each respective one of the sensed operating conditions to a corresponding normal operating condition for each respective one of the at least one sensed operating condition of the motor (9) and for determining when the motor is operating significantly outside the corresponding normal operating condition for the motor (9) for a given period of time. 30
11. The subsystem of claim 1, wherein the performer (94) further comprises a power stage (38, 50) for controlling the provision of power to the motor. 35
12. The subsystem of claim 11, further comprising a timer (82) for timing if the motor (9) has been powered on for more than a predetermined amount of time, and a timer subcontrol (84) for instructing the power stage (86) to cease providing power to the motor when the timer times for the predetermined amount of time. 40
13. The subsystem of claim 9, wherein the performer (94) also comprises the microcontroller, and, where- 45
- in the module further comprises: a power stage comprising a triac (40) for controlling the provision of power to the motor and the microcontroller controls the triac (40) by providing triac gate drive signals (42).
14. The subsystem of claim 1, wherein the comparator (94) determines if the motor current is in an overcurrent condition and the performer (94) acts on a determined overcurrent condition. 50
15. The subsystem of claim 1, wherein the comparator (94) determines if the motor current is in an undercurrent condition and the performer (94) acts on a determined undercurrent condition. 55
16. The subsystem of claim 1, further comprising memory and a learn mode wherein the module senses each operating condition for the motor through the sensor for that condition and stores the condition in memory for future use as a normal operating condition for the motor (9).
17. The subsystem of claim 6 wherein the remote module comprises a remote control module (5) comprising a radio frequency wireless receiver for wirelessly receiving radio frequency messages from the central vacuum source control module (3).
18. The subsystem of claim 17, wherein the remote control module (5) further comprises a user interface for providing the messages from the central vacuum source control module (3) to a user of the central vacuum cleaning system.
19. The subsystem of claim 18, wherein the remote control module user interface comprises a display for displaying to the user messages from the central vacuum source control module.
20. The subsystem of claim 17, wherein the remote control module comprises: a user interface for providing an alert to a user of the central vacuum cleaning system, the user interface including at least one of a display (75) or a transducer for generating the user alert.
21. A method of controlling a central vacuum cleaning system suction motor (9), the method comprising:
- a) sensing at least one operating condition of the motor (9), such at least one operating condition including the motor current;
 - b) comparing each sensed operating condition to a corresponding normal operating condition for that sensed operating condition of the motor (9);
 - c) determining when the motor is operating significantly outside at least one normal operating

- condition for the motor (9) for a given period of time; and
 d) when it is determined that the motor is operating significantly outside the normal operating condition for the motor current, performing at least one action, wherein the action includes providing a message to a user (11) in a location remote from the motor (9) that the cleaning system is operating significantly outside normal operating conditions.
22. The method of claim 21, wherein the at least one action comprises shutting down the motor (9).
23. The method of claim 22, wherein shutting down the motor comprises turning off a triac (40) that controls flow of current to the motor (9).
24. The method of claim 21, wherein when the motor current is operating significantly above normal operating current for the motor (9), the at least one action comprises shutting down the motor (9).
25. The method of claim 21, wherein when the motor current is operating significantly above normal operating current for the motor (9), the at least one action comprises providing a message to the user (11).
26. The method of claim 21, wherein the message to a user (11) that the cleaning system is operating significantly outside normal operating conditions is provided through a display screen or a transducer.
27. The method of claim 21, wherein when the motor current is operating significantly below normal operating current for the motor (9), the at least one action comprises providing a message to the user (11).
28. The method of claim 27, wherein providing a message to the user (11) comprises providing a message to the user (11) through a user interface on a hose handle (20, 213) of the cleaning system.
29. The method of claim 28, wherein providing a message to the user comprises providing a message to the user (11) through one or more LEDs comprised in the hose handle (20, 213).
30. The method of claim 28, wherein providing a message to the user comprises providing a message to the user (11) through an LCD screen comprised in the hose handle (20, 213).
31. The method of claim 28, wherein alerting the user comprises providing a message to the user (11) through one or more audible devices comprised in the hose handle (20, 213).
32. The method of claim 28, wherein providing a message to the user comprises providing a message to the user (11) through a speaker comprised in the hose handle (20, 213).
33. The method of claim 32, wherein providing a message to the user (11) comprises providing a message to the user via voice prompts through the speaker.
34. The method of claim 28, wherein providing a message to the user comprises providing a message to the user (11) through a buzzer comprised in the hose handle (20, 213).
35. The method of claim 27, wherein providing a message to the user (11) comprises providing a message to the user (11) through a user interface in a remote station separate from a hose handle (20, 213) of the cleaning system and separate from a canister that houses the motor (9).
36. The method of claim 35, wherein the remote station comprises an LCD screen through which the user views information about the operating condition of the motor (9).
37. The method of claim 21, wherein at least one normal operating condition is, prior to sensing the operating condition of the motor, learned by:
- operating the motor under normal operating conditions for the motor,
 - sensing the at least one normal operating condition for determination, and
 - storing the sensed at least one normal operating condition.
38. The method of claim 35, wherein after normal operating condition learning, and prior to sensing the operating condition of the motor (9), the at least one normal operation condition is optionally re-learned by following the procedure for learning the at least one normal operating condition.
39. The method of claim 21, wherein at least one normal operating condition, prior to sensing the operating condition of the motor (9), is stored.

Patentansprüche

- Zentrales Staubsaugsystemsteueruntersystem (1) für den Gebrauch in einem zentralen Staubsaugsystem, das einen Saugmotor (9) hat, wobei das Untersystem ein zentrales Vakuumquellensteuermodul (3) zum Steuern eines Saugmotors des zentralen Staubsaugsystems aufweist, wobei das Modul Folgendes aufweist:

- a) mindestens einen Sensor (92), wobei jeder Sensor einen jeweiligen Betriebszustand des Motors (9) erfasst, einen Stromsensor des mindestens einen Sensors zum Erfassen des Motorstroms des Motors (9),
- b) mindestens einen Komparator (94), wobei jeder Komparator (94) jeden erfassten Betriebszustand des mindestens einen erfassten Betriebszustands mit einem entsprechenden normalen Betriebszustand für den erfassten Betriebszustand des Motors (9) vergleicht, und bestimmt, wann der Motor (9) während einer gegebenen Zeitspanne signifikant außerhalb mindestens eines entsprechenden normalen Betriebszustands für den Motor (9) funktioniert, und
- c) eine durchführende Arbeitseinheit (94), um, wenn der Komparator bestimmt, dass der Motor signifikant außerhalb des normalen Betriebszustands für den Motorstrom funktioniert, mindestens eine Aktion auszuführen, wobei die Aktion das Übertragen einer Meldung zu einem dezentralen Modul (5) aufweist, um eine Benutzerwarnung an dem dezentralen Modul zu erzeugen.
2. Untersystem nach Anspruch 1, wobei die durchführende Arbeitseinheit (94) den Motor (9) abschaltet, wenn der Komparator (94) bestimmt, dass der Motorstrom signifikant außerhalb des normalen Betriebszustands für den Motorstrom funktioniert.
3. Untersystem nach Anspruch 1, wobei die durchführende Arbeitseinheit (94) aufhört, Strom zu dem Motor zu liefern, wenn der Komparator bestimmt, dass der Motor (9) signifikant außerhalb des normalen Betriebszustands für den Motorstrom funktioniert.
4. Untersystem nach Anspruch 1, wobei die durchführende Arbeitseinheit (94) aufhört, Strom zu dem Motor (9) zu liefern, wenn der Komparator bestimmt, dass der Motor signifikant außerhalb des normalen Betriebszustands für den Motorstrom funktioniert, so dass der Motorstrom in einem Überstromzustand ist.
5. Untersystem nach Anspruch 1, wobei die durchführende Arbeitseinheit (94) eine Benutzerwarnung bereitstellt, wenn der Komparator (94) bestimmt, dass der Motor signifikant außerhalb des normalen Betriebszustands für den Motorstrom funktioniert, so dass der Motorstrom in einem Überstromzustand ist.
6. Untersystem nach Anspruch 1, wobei die durchführende Arbeitseinheit einen drahtlosen Funkfrequenzsender aufweist und wobei die durchführende Arbeitseinheit (94) eine drahtlose Funkfrequenzmeldung übermittelt, wenn der Komparator bestimmt, dass der Motor (9) signifikant außerhalb des normalen Betriebszustands für den Motorstrom funktioniert.
7. Untersystem nach Anspruch 1, wobei der mindestens eine Sensor eine Vielzahl von Sensoren ist, darunter der Stromsensor (98) und ein Temperatursensor (104) zum Erfassen von Temperatur um den Motor (9).
8. Untersystem nach Anspruch 1, wobei der mindestens eine Sensor eine Vielzahl von Sensoren ist, darunter der Stromsensor (98) und ein Schwingungssensor (106) zum Erfassen von Schwingungen.
9. Untersystem nach Anspruch 1, wobei der mindestens eine Komparator einen Mikrocontroller zum Vergleichen eines jeweiligen des mindestens einen erfassten Betriebszustand mit einem entsprechenden normalen Betriebszustand für den erfassten Betriebszustand des Motors (9) und zum Bestimmen, wann der Motor (9) signifikant außerhalb des entsprechenden normalen Betriebszustands für den Motor während einer gegebenen Zeitspanne funktioniert, aufweist.
10. Untersystem nach Anspruch 1, wobei der mindestens eine Komparator (94) einen Mikrocontroller zum Vergleichen jedes jeweiligen der erfassten Betriebszustände mit einem entsprechenden normalen Betriebszustand für jeden jeweiligen des mindestens einen erfassten Betriebszustands des Motors (9) und zum Bestimmen, wann der Motor während einer gegebenen Zeitspanne signifikant außerhalb des entsprechenden normalen Betriebszustand für den Motor (9) funktioniert, aufweist.
11. Untersystem nach Anspruch 1, wobei die durchführende Arbeitseinheit (94) ferner eine Leistungsstufe (38, 50) zum Steuern der Bereitstellung von Leistung zu dem Motor aufweist.
12. Untersystem nach Anspruch 11, das ferner einen Timer (82) zum Messen aufweist, ob der Motor (9) länger als eine vorbestimmte Zeitspanne mit Leistung versorgt wurde, und eine Timer-Untersteuerung (84), um die Leistungsstufe (86) anzuweisen, das Bereitstellen von Leistung zu dem Motor einzustellen, wenn der Timer die vorbestimmte Zeitspanne misst.
13. Untersystem nach Anspruch 9, wobei die durchführende Arbeitseinheit (94) auch den Mikrocontroller aufweist und wobei das Modul ferner Folgendes aufweist: eine Leistungsstufe, die ein Triac (40) zum Steuern der Bereitstellung von Leistung zu dem Motor aufweist und der Mikrocontroller das Triac (40) durch Bereitstellen von Triac-Gate-Treibersignalen (42) steuert.

14. Untersystem nach Anspruch 1, wobei der Komparator (94) bestimmt, ob der Motorstrom in einem Überstromzustand ist, und wobei die durchführende Arbeitseinheit (94) auf einen bestimmten Überstromzustand wirkt. 5
15. Untersystem nach Anspruch 1, wobei der Komparator (94) bestimmt, ob der Motorstrom in einem Unterstromzustand ist und wobei die durchführende Arbeitseinheit (94) auf einen bestimmten Unterstromzustand wirkt. 10
16. Untersystem nach Anspruch 1, das ferner einen Speicher und einen Lernmodus aufweist, wobei das Modul jeden Betriebszustand für den Motor durch den Sensor für diesen Zustand erfasst und den Zustand im Speicher für zukünftigen Gebrauch als einen normalen Betriebszustand für den Motor (9) speichert. 15
17. Untersystem nach Anspruch 6, wobei das dezentrale Modul ein dezentrales Steuermodul (5) aufweist, das einen drahtlosen Funkfrequenzempfänger zum drahtlosen Empfangen von Funkfrequenzmeldungen von dem zentralen Staubsaug-Quellensteuermodul (3) aufweist. 20
18. Untersystem nach Anspruch 17, wobei das dezentrale Steuermodul (5) eine Benutzeroberfläche zum Bereitstellen der Meldungen von dem zentralen Staubsaug-Quellensteuermodul (3) zu einem Benutzer des zentralen Staubsaugsystems aufweist. 25
19. Untersystem nach Anspruch 18, wobei die dezentrale Steuermodul-Benutzeroberfläche ein Display zum Anzeigen der Benutzermeldungen von dem zentralen Vakuumquellensteuermodul aufweist. 30
20. Untersystem nach Anspruch 17, wobei das dezentrale Steuermodul eine Benutzeroberfläche zum Bereitstellen einer Warnung zu einem Benutzer des zentralen Staubsaugsystems aufweist, wobei die Benutzeroberfläche mindestens ein Display (75) und/oder einen Messgrößenumformer zum Erzeugen der Benutzerwarnung aufweist. 35
21. Verfahren zum Steuern des Saugmotors (9) eines zentralen Staubsaugsystems, wobei das Verfahren Folgendes aufweist: 40
- a) Erfassen mindestens eines Betriebszustands des Motors (9), wie zum Beispiel mindestens eines Betriebszustands, der den Motorstrom aufweist,
- b) Vergleichen jedes erfassten Betriebszustands mit einem entsprechenden normalen Betriebszustand für den erfassten Betriebszustand des Motors (9),
- c) Bestimmen, wann der Motor während einer gegebenen Zeitspanne signifikant außerhalb mindestens eines normalen Betriebszustands für den Motor (9) funktioniert, und
- d) wenn bestimmt wird, dass der Motor signifikant außerhalb des normalen Betriebszustands für den Motorstrom funktioniert, Ausführen mindestens einer Aktion, wobei die Aktion das Bereitstellen einer Meldung zu einem Benutzer (11), dass das Reinigungssystem signifikant außerhalb normaler Betriebszustände funktioniert, an einer Stelle entfernt von dem Motor (9) aufweist. 45
22. Verfahren nach Anspruch 21, wobei die mindestens eine Aktion das Abschalten des Motors (9) aufweist.
23. Verfahren nach Anspruch 22, wobei das Abschalten des Motors das Abschalten eines Triac (40) aufweist, der das Strömen von Strom zu dem Motor (9) steuert. 50
24. Verfahren nach Anspruch 21, wobei, wenn der Motorstrom signifikant oberhalb des normalen Betriebsstroms für den Motor (9) funktioniert, die mindestens eine Aktion das Abschalten des Motors (9) aufweist.
25. Verfahren nach Anspruch 21, wobei, wenn der Motorstrom signifikant oberhalb des normalen Betriebsstroms für den Motor (9) funktioniert, die mindestens eine Aktion das Bereitstellen einer Meldung zu dem Benutzer (11) aufweist.
26. Verfahren nach Anspruch 21, wobei die Meldung, dass das Reinigungssystem signifikant außerhalb normaler Betriebszustände funktioniert, durch ein Display oder einen Messgrößenumformer zu einem Benutzer (11) bereitgestellt wird.
27. Verfahren nach Anspruch 21, wobei, wenn der Motorstrom signifikant unterhalb normalem Betriebsstrom für den Motor (9) funktioniert, die mindestens eine Aktion das Bereitstellen einer Meldung zu dem Benutzer (11) aufweist.
28. Verfahren nach Anspruch 27, wobei das Bereitstellen einer Meldung zu dem Benutzer (11) das Bereitstellen einer Meldung zu dem Benutzer (11) durch eine Benutzeroberfläche auf einem Schlauchgriff (20, 213) des Reinigungssystems aufweist. 55
29. Verfahren nach Anspruch 28, wobei das Bereitstellen einer Meldung zu dem Benutzer das Bereitstellen einer Meldung zu dem Benutzer (11) über eine oder mehrere LEDs, die in dem Schlauchgriff (20, 213) enthalten sind, aufweist.
30. Verfahren nach Anspruch 28, wobei das Bereitstellen einer Meldung zu dem Benutzer das Bereitstellen

- einer Meldung zu dem Benutzer (11) über ein LCD, das in dem Schlauchgriff (20, 213) enthalten ist, aufweist.
31. Verfahren nach Anspruch 28, wobei das Warnen des Benutzers das Bereitstellen einer Meldung zu dem Benutzer (11) über eine oder mehrere hörbare Vorrichtungen, die in dem Schlauchgriff (20, 213) enthalten sind, aufweist. 5
32. Verfahren nach Anspruch 28, wobei das Bereitstellen einer Meldung zu dem Benutzer das Bereitstellen einer Meldung zu dem Benutzer (11) über einen Lautsprecher, der in dem Schlauchgriff (20, 213) enthalten ist, aufweist. 10
33. Verfahren nach Anspruch 32, wobei das Bereitstellen einer Meldung zu dem Benutzer (11) das Bereitstellen einer Meldung zu dem Benutzer über Sprachaufforderungen durch den Lautsprecher aufweist. 20
34. Verfahren nach Anspruch 28, wobei das Bereitstellen einer Meldung zu dem Benutzer das Bereitstellen einer Meldung zu dem Benutzer (11) durch einen Summer, der in dem Schlauchgriff (20, 213) enthalten ist, aufweist. 25
35. Verfahren nach Anspruch 27, wobei das Bereitstellen einer Meldung zu dem Benutzer (11) das Bereitstellen einer Meldung zu dem Benutzer (11) über eine Benutzeroberfläche in einer dezentralen Station, getrennt von einem Schlauchgriff (20, 213) des Reinigungssystems und getrennt von einem Behälter, der den Motor (9) aufnimmt, aufweist. 30
36. Verfahren nach Anspruch 35, wobei die dezentrale Station ein LCD aufweist, durch welches der Benutzer Informationen über den Betriebszustand des Motors (9) sieht. 35
37. Verfahren nach Anspruch 21, wobei mindestens ein normaler Betriebszustand vor dem Erfassen des Betriebszustands des Motors gelernt wird durch:
- a) Betreiben des Motors unter normalen Betriebszuständen für den Motor, 45
 - b) Erfassen des mindestens einen normalen Betriebszustands zum Bestimmen und
 - c) Speichern des erfassten mindestens einen normalen Betriebszustands. 50
38. Verfahren nach Anspruch 35, wobei der mindestens eine normale Betriebszustand nach dem Lernen des normalen Betriebszustands und vor dem Erfassen des Betriebszustands des Motors (9) optional durch Befolgen der Vorgehensweise zum Lernen des mindestens einen normalen Betriebszustands neu gelernt wird. 55

39. Verfahren nach Anspruch 21, wobei mindestens ein normaler Betriebszustand vor dem Erfassen des Betriebszustands des Motors (9) gespeichert wird.

Revendications

1. Sous-système (1) de commande de système central de nettoyage par aspiration destiné à être utilisé dans un système central de nettoyage par aspiration présentant un moteur d'aspiration (9), le sous-système comprenant un module central (3) de commande de source de vide destiné à contrôler un moteur d'aspiration de système central de nettoyage par aspiration, le module comprenant:
 - a) au moins un capteur (92), chaque capteur détectant une condition de fonctionnement respective du moteur (9), un capteur de courant de l'au moins un capteur destiné à détecter le courant de moteur (9);
 - b) au moins un comparateur (94), chaque comparateur (94) comparant chaque condition de fonctionnement détectée parmi l'au moins une condition de fonctionnement détectée avec une condition de fonctionnement normale correspondante pour cette condition de fonctionnement du moteur (9) et déterminant si le moteur (9) fonctionne considérablement en-dehors de l'au moins une condition de fonctionnement normale correspondante pour le moteur (9) pendant un laps de temps donné; et
 - c) un réalisateur (94) destiné à réaliser, lorsque le comparateur détermine que le moteur fonctionne considérablement en-dehors de la condition de fonctionnement normale pour le courant de moteur, au moins une action, l'action comprenant le fait de transmettre un message à un module éloigné (5) pour générer une alarme d'utilisateur au module éloigné.
2. Sous-système selon la revendication 1, dans lequel le réalisateur (94) arrête le moteur (9) lorsque le comparateur (94) détermine que le courant du moteur fonctionne considérablement en-dehors de la condition de fonctionnement normale pour le courant du moteur.
3. Sous-système selon la revendication 1, dans lequel le réalisateur (94) cesse de fournir du courant au moteur lorsque le comparateur détermine que le moteur (9) fonctionne considérablement en-dehors de la condition de fonctionnement normale pour le courant du moteur.
4. Sous-système selon la revendication 1, dans lequel le réalisateur (94) cesse de fournir du courant au moteur (9) lorsque le comparateur détermine que le

- moteur fonctionne considérablement en-dehors de la condition de fonctionnement normale pour le courant du moteur de sorte que le courant du moteur est en condition de surcourant.
5. Sous-système selon la revendication 1, dans lequel le réalisateur (94) fournit une alarme d'utilisateur lorsque le comparateur (94) détermine que le moteur fonctionne considérablement en-dehors de la condition de fonctionnement normale pour le courant de moteur de sorte que le courant de moteur est en condition de surcourant.
 6. Sous-système selon la revendication 1, dans lequel le réalisateur comprend un émetteur sans fil à radiofréquence et le réalisateur (94) transmet un message sans fil à radiofréquence lorsque le comparateur détermine que le moteur (9) fonctionne considérablement en-dehors de la condition de fonctionnement normale pour le courant de moteur.
 7. Sous-système selon la revendication 1, dans lequel l'au moins un capteur est une pluralité de capteurs comprenant le capteur de courant (98) et le capteur de température (104) destiné à détecter la température autour du moteur (9).
 8. Sous-système selon la revendication 1, dans lequel l'au moins un capteur est une pluralité de capteurs comprenant un capteur de courant (98) et un capteur de vibrations (106) destiné à détecter les vibrations.
 9. Sous-système selon la revendication 1, dans lequel l'au moins un comparateur comprend un microcontrôleur destiné à comparer l'une respective des au moins une condition de fonctionnement détectée avec une condition de fonctionnement normale correspondante pour cette condition de fonctionnement détectée du moteur (9) et déterminer le moment où le moteur (9) fonctionne considérablement en-dehors de la condition de fonctionnement normale correspondante du moteur pendant un laps de temps donné.
 10. Sous-système selon la revendication 1, dans lequel l'au moins un comparateur (94) comprend un microcontrôleur destiné à comparer chaque condition respective parmi les conditions de fonctionnement détectées avec une condition de fonctionnement normale correspondante pour chaque condition respective parmi les au moins une condition de fonctionnement détectée du moteur (9) et à déterminer si le moteur fonctionne considérablement en-dehors de la condition de fonctionnement normale correspondante pour le moteur (9) pendant un laps de temps donné.
 11. Sous-système selon la revendication 1, dans lequel le réalisateur (94) comprend par ailleurs un étage d'énergie (38, 50) destiné à commander la fourniture d'énergie au moteur.
 12. Sous-système selon la revendication 11, comprenant par ailleurs un temporisateur (82) destiné à retarder si le moteur (9) a été alimenté pendant plus d'une quantité de temps prédéterminée, et une sous-commande de temporisateur (84) destinée à donner instruction à l'étage d'énergie (86) de cesser de fournir de l'énergie au moteur lorsque le temporisateur retarde de la quantité de temps prédéterminée.
 13. Sous-système selon la revendication 9, dans lequel le réalisateur (94) comprend également le microcontrôleur, et dans lequel le module comprend par ailleurs un étage d'énergie comprenant un triac (40) destiné à commander la fourniture de l'énergie au moteur et le microcontrôleur commande le triac (40) en fournissant des signaux de commande de porte de triac (42).
 14. Sous-système selon la revendication 1, dans lequel le comparateur (94) détermine si le courant du moteur est en condition de surcourant et le réalisateur (94) agit sur une condition de surcourant déterminée.
 15. Sous-système selon la revendication 1, dans lequel le comparateur (94) détermine si le courant du moteur fonctionne en condition de sous-courant et le réalisateur (94) agit sur une condition de sous-courant déterminée.
 16. Sous-système selon la revendication 1, comprenant par ailleurs une mémoire et un mode d'apprentissage dans lequel le module détecte chaque condition de fonctionnement pour le moteur par l'intermédiaire du capteur pour cette condition et mémorise la condition en mémoire pour être utilisée ultérieurement comme condition de fonctionnement normale pour le moteur (9).
 17. Sous-système selon la revendication 6, dans lequel le module éloigné comprend un module de commande à distance (5) comprenant un récepteur sans fil à radiofréquence recevant les messages à radiofréquence du module de commande de source de vide.
 18. Sous-système selon la revendication 17, dans lequel le module de commande à distance (5) comprend par ailleurs une interface d'utilisateur destinée à fournir les messages du module de commande central de source de vide (3) à un utilisateur du système central de nettoyage par aspiration.
 19. Sous-système selon la revendication 18, dans lequel l'interface d'utilisateur du module de commande à distance comprend un écran d'affichage destiné à

- afficher les messages d'utilisateur du module de commande central de source de vide.
20. Sous-système selon la revendication 17, dans lequel le module de commande à distance comprend une interface d'utilisateur destinée à fournir une alarme à l'utilisateur du système central de nettoyage par aspiration, l'interface d'utilisateur comportant au moins l'un parmi un écran d'affichage (75) ou un transducteur destiné à générer l'alarme d'utilisateur.
21. Procédé de commande d'un moteur d'aspiration de système central de nettoyage par aspiration (9), le procédé comprenant:
- détecter au moins une condition de fonctionnement du moteur (9), telle qu'au moins une condition de fonctionnement comportant le courant du moteur;
 - comparer chaque condition de fonctionnement détectée avec une condition de fonctionnement normale correspondante pour cette condition de fonctionnement détectée du moteur (9);
 - déterminer si le moteur fonctionne considérablement en-dehors d'au moins une condition de fonctionnement normale pour le moteur (9) pendant un laps de temps donné; et
 - lorsqu'il est déterminé que le moteur fonctionne considérablement en-dehors de la condition de fonctionnement normale pour le courant du moteur, réaliser au moins une action, où l'action comporte le fait de fournir un message à un utilisateur (11) à un endroit éloigné du moteur (9) que le système de nettoyage fonctionne considérablement en-dehors des conditions de fonctionnement normales.
22. Procédé selon la revendication 21, dans lequel l'au moins une action comprend le fait d'arrêter le moteur (9).
23. Procédé selon la revendication 22, dans lequel le fait d'arrêter le moteur comprend le fait de couper un triac (40) qui commande le flux de courant vers le moteur (9).
24. Procédé selon la revendication 21, dans lequel, si le moteur fonctionne considérablement au-dessus du courant de fonctionnement normal pour le moteur (9), l'au moins une action comprend le fait d'arrêter le moteur (9).
25. Procédé selon la revendication 21, dans lequel, si le moteur fonctionne considérablement au-dessus du courant de fonctionnement normal pour le moteur (9), l'au moins une action comprend le fait de fournir un message à l'utilisateur (11).
26. Procédé selon la revendication 21, dans lequel le message à un utilisateur (11) que le système de nettoyage fonctionne considérablement en-dehors des conditions de fonctionnement normales est fourni par l'intermédiaire d'un écran d'affichage ou d'un transducteur.
27. Procédé selon la revendication 21, dans lequel, si le moteur fonctionne considérablement au-dessous du courant de fonctionnement normal pour le moteur (9), l'au moins une action comprend le fait de fournir un message à l'utilisateur (11).
28. Procédé selon la revendication 27, dans lequel le fait de fournir un message à l'utilisateur (11) comprend le fait de fournir un message à l'utilisateur (11) par l'intermédiaire d'une interface d'utilisateur sur une poignée de flexible (20, 213) du système de nettoyage.
29. Procédé selon la revendication 28, dans lequel le fait de fournir un message à l'utilisateur comprend le fait de fournir un message à l'utilisateur (11) par l'intermédiaire d'un ou plusieurs DEL comprises dans la poignée de flexible (20, 213).
30. Procédé selon la revendication 28, dans lequel le fait de fournir un message à l'utilisateur comprend le fait de fournir un message à l'utilisateur (11) par l'intermédiaire d'un écran LCD compris dans la poignée de flexible (20, 213).
31. Procédé selon la revendication 28, dans lequel le fait d'alerter l'utilisateur comprend le fait de fournir un message à l'utilisateur (11) par l'intermédiaire d'un ou plusieurs dispositifs audibles compris dans la poignée de flexible (20, 213).
32. Procédé selon la revendication 28, dans lequel le fait de fournir un message à l'utilisateur comprend le fait de fournir un message à l'utilisateur (11) par l'intermédiaire d'un haut-parleur compris dans la poignée de flexible (20, 213).
33. Procédé selon la revendication 32, dans lequel le fait de fournir un message à l'utilisateur (11) comprend le fait de fournir un message à l'utilisateur par l'intermédiaire de messages verbaux à travers le haut-parleur.
34. Procédé selon la revendication 28, dans lequel le fait de fournir un message à l'utilisateur comprend le fait de fournir un message à l'utilisateur (11) par l'intermédiaire d'un ronfleur compris dans la poignée de flexible (20, 213).
35. Procédé selon la revendication 27, dans lequel le fait de fournir un message à l'utilisateur (11) com-

- prend le fait de fournir un message à l'utilisateur (11) par l'intermédiaire d'une interface d'utilisateur dans une station à distance séparée d'une poignée de flexible (20, 213) du système de nettoyage et séparée d'une boîte qui contient le moteur (9). 5
36. Procédé selon la revendication 35, dans lequel la station à distance comprend un écran LCD par l'intermédiaire duquel l'utilisateur visionne l'information sur la condition de fonctionnement du moteur (9). 10
37. Procédé selon la revendication 21, dans lequel l'au moins une condition de fonctionnement normale est, avant de détecter la condition de fonctionnement du moteur, apprise: 15
- a) en faisant fonctionner le moteur dans des conditions de fonctionnement normales pour le moteur,
 - b) en détectant l'au moins une condition de fonctionnement normale pour la détermination, et 20
 - c) en mémorisant l'au moins une condition de fonctionnement normale détectée.
38. Procédé selon la revendication 35, dans lequel, après apprentissage de la condition de fonctionnement normale et avant de détecter la condition de fonctionnement du moteur (9), l'au moins une condition de fonctionnement normale est optionnellement réapprise en suivant la procédure pour l'apprentissage de l'au moins une condition de fonctionnement normale. 25 30
39. Procédé selon la revendication 21, dans lequel l'au moins une condition de fonctionnement normale est mémorisée avant de détecter la condition de fonctionnement du moteur (9). 35

40

45

50

55

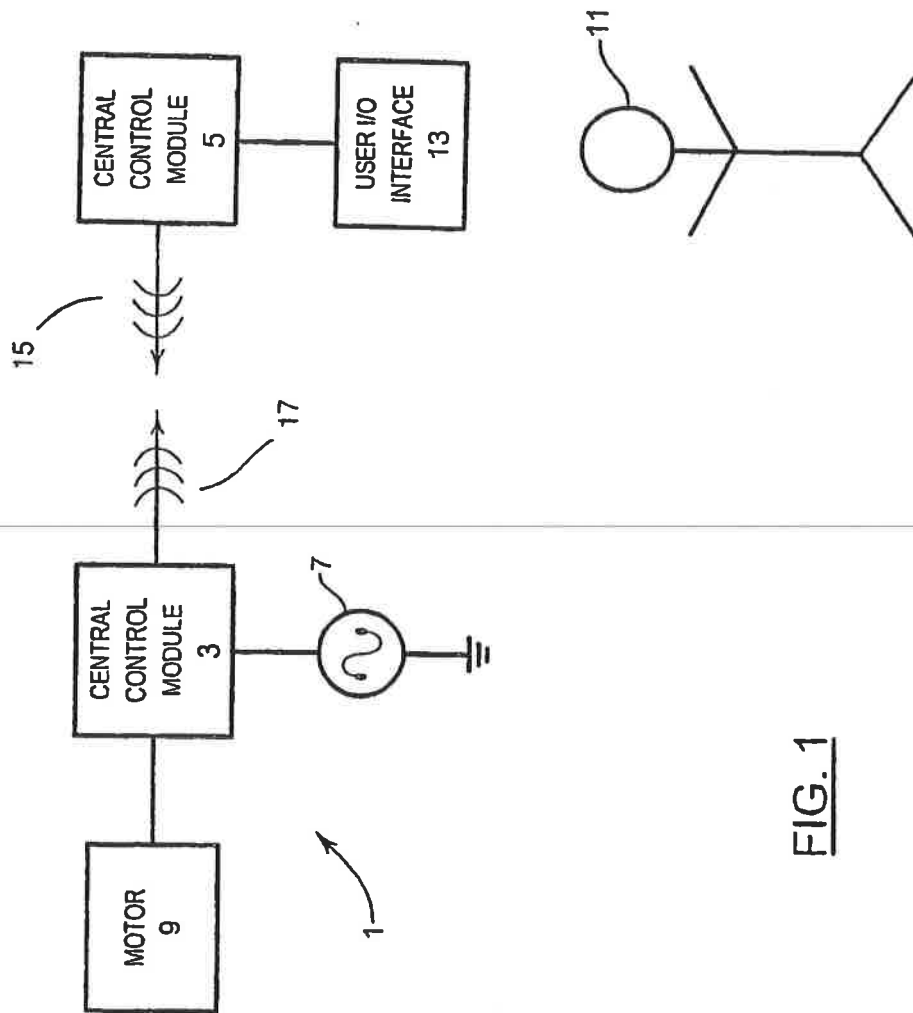

FIG. 1

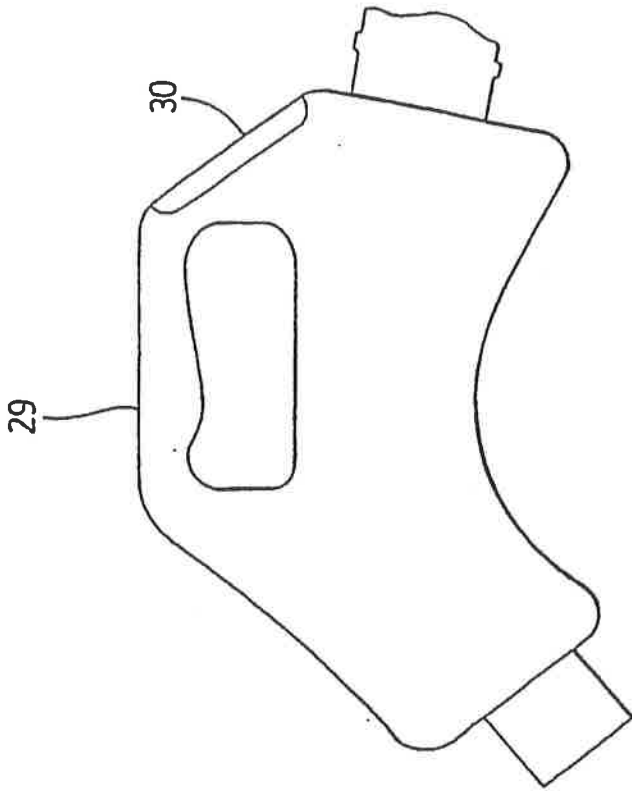

FIG. 3

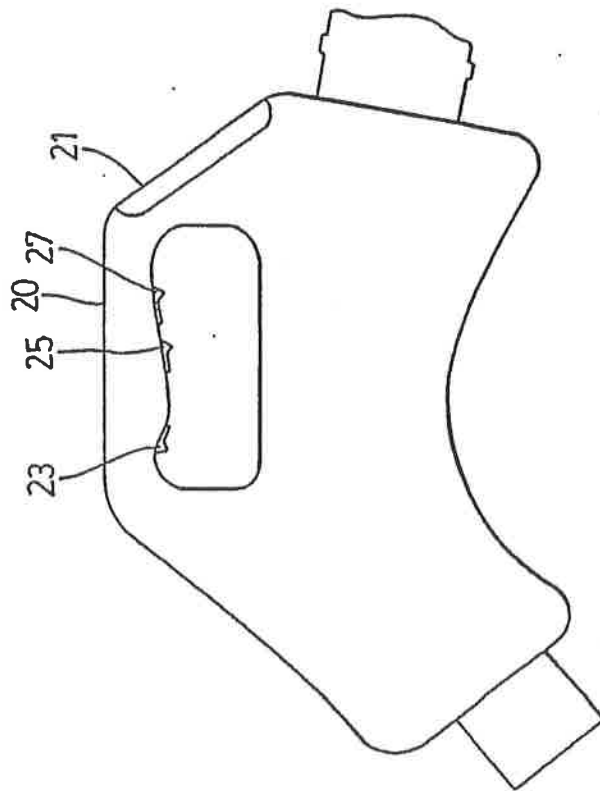

FIG. 2

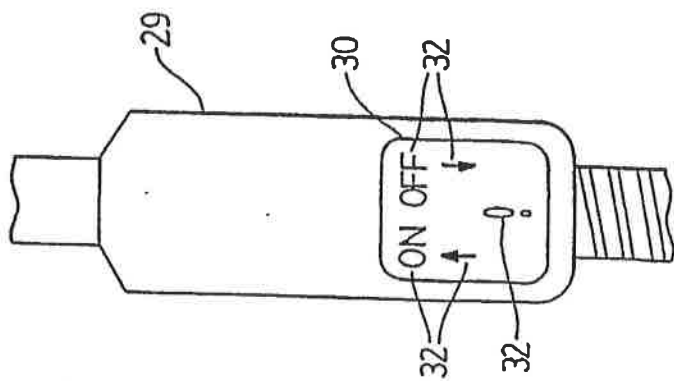

FIG. 4

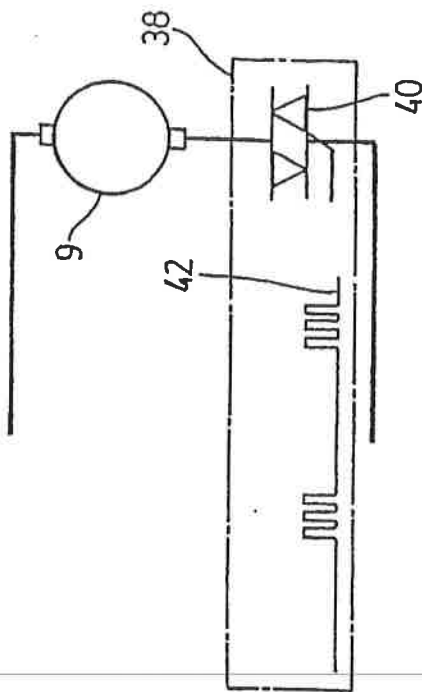

FIG. 5

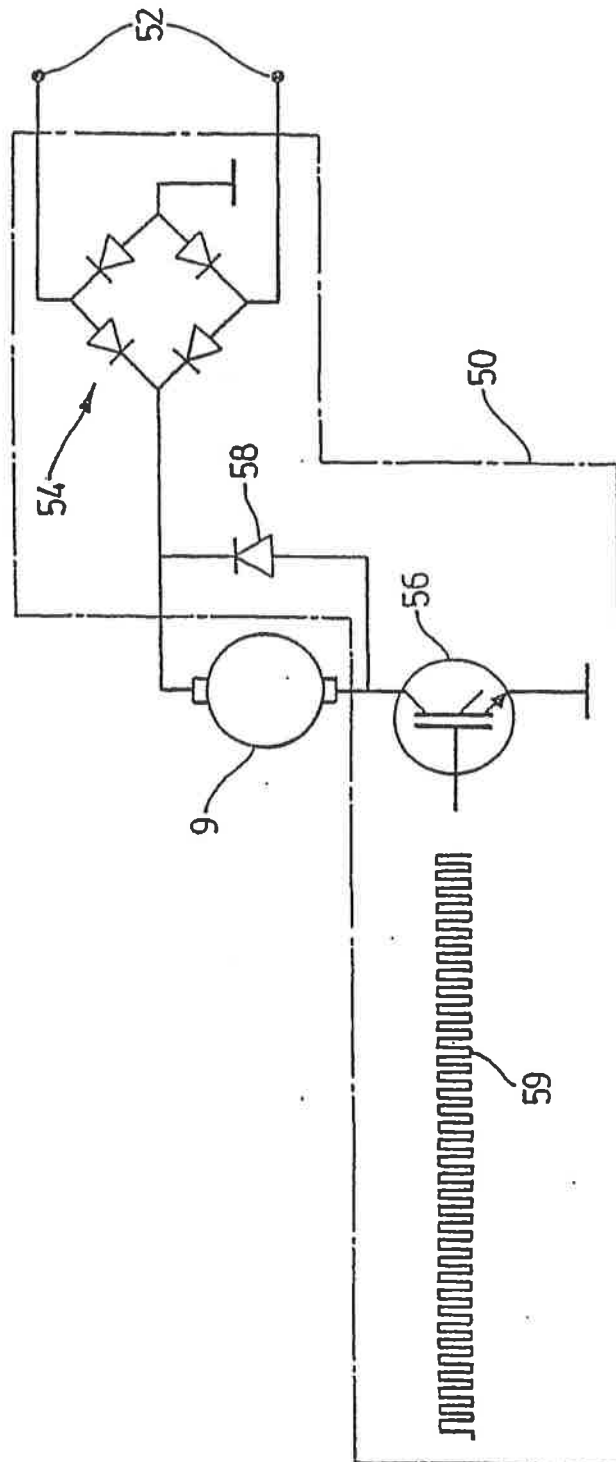

FIG. 6

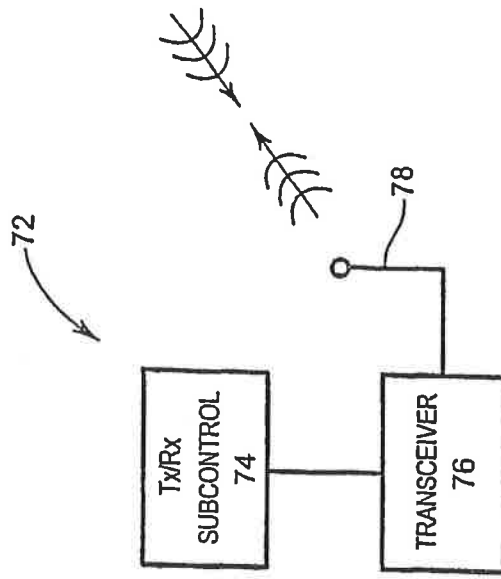

FIG. 9

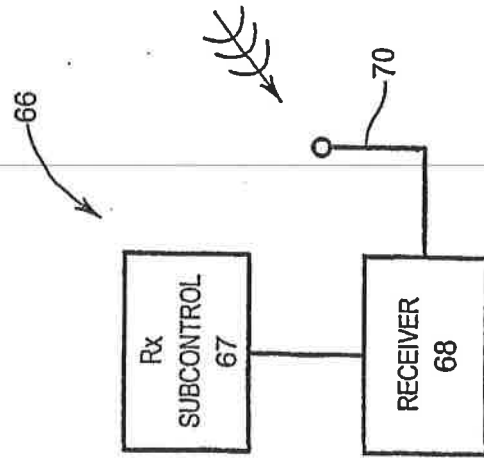

FIG. 8

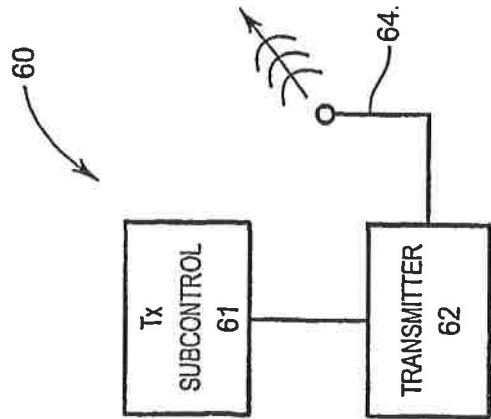

FIG. 7

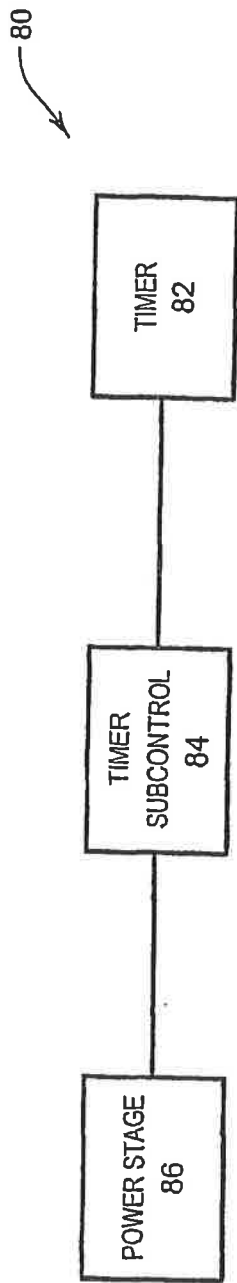

FIG. 10

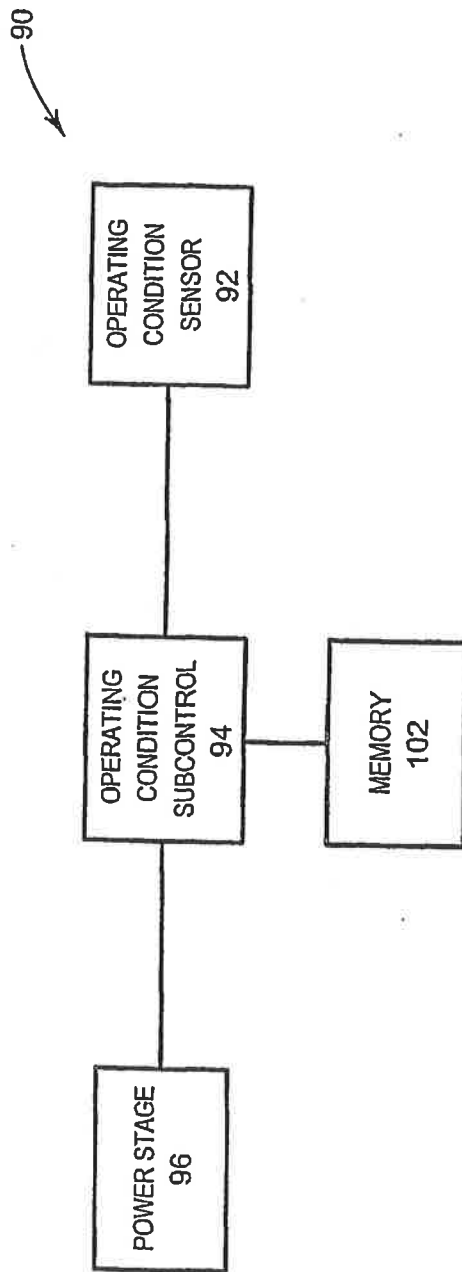

FIG. 11

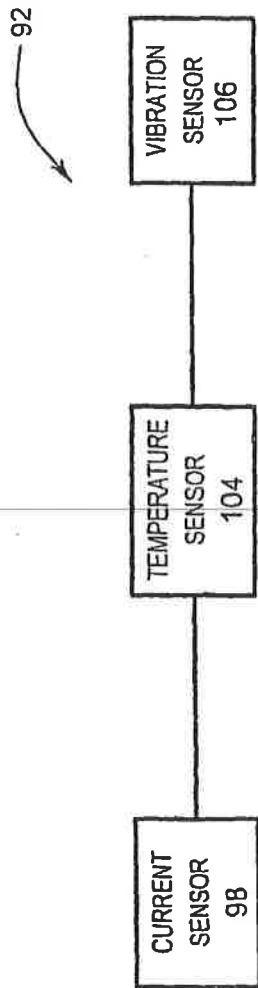

FIG. 12

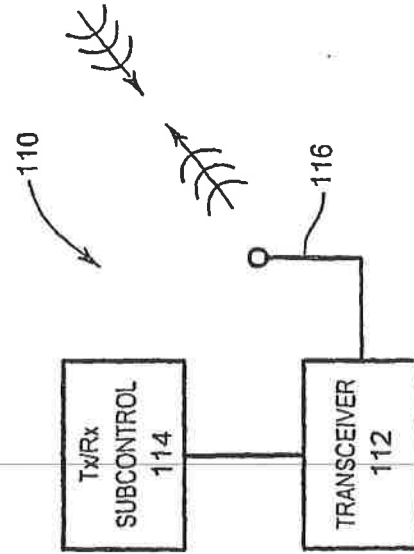

FIG. 13

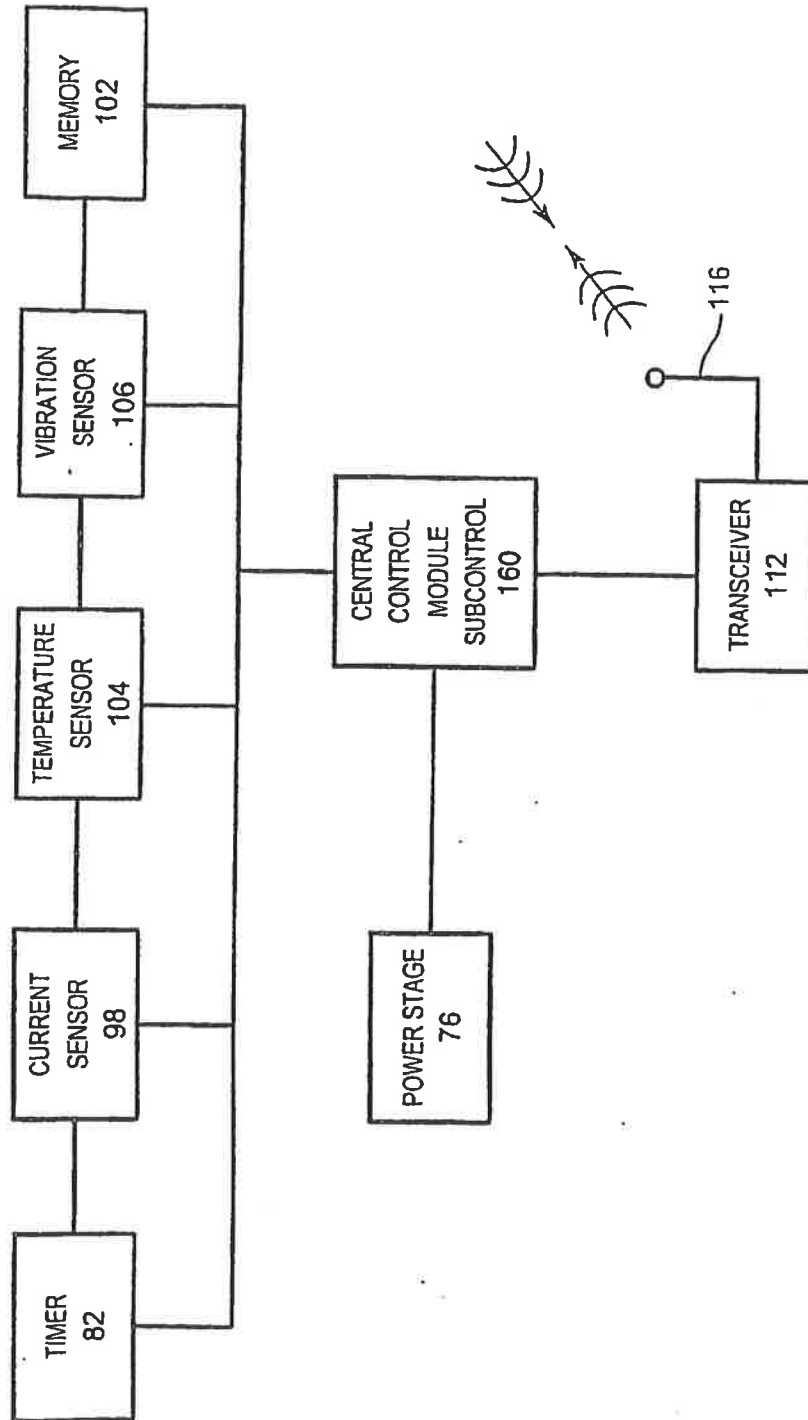

FIG. 14

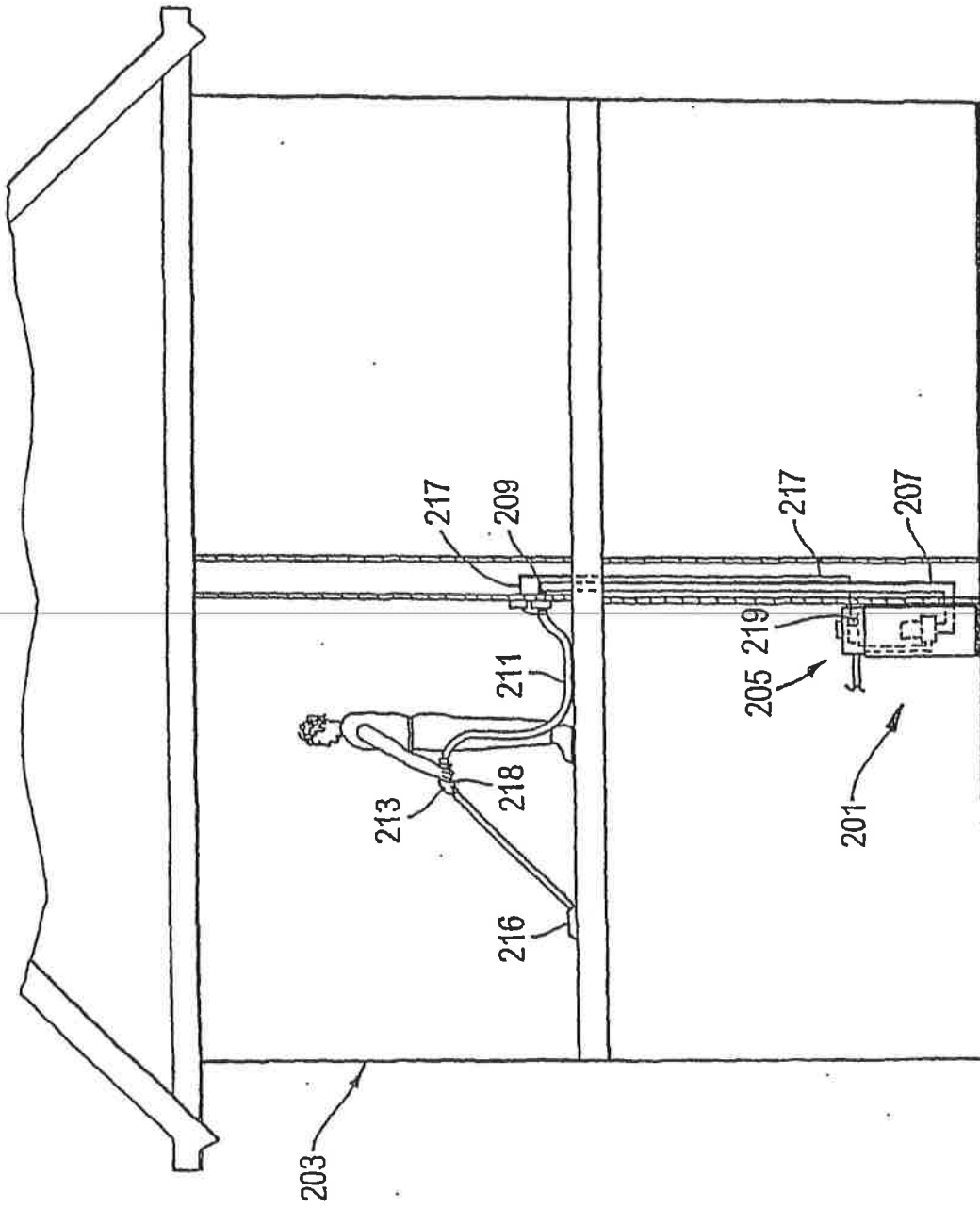

FIG. 15

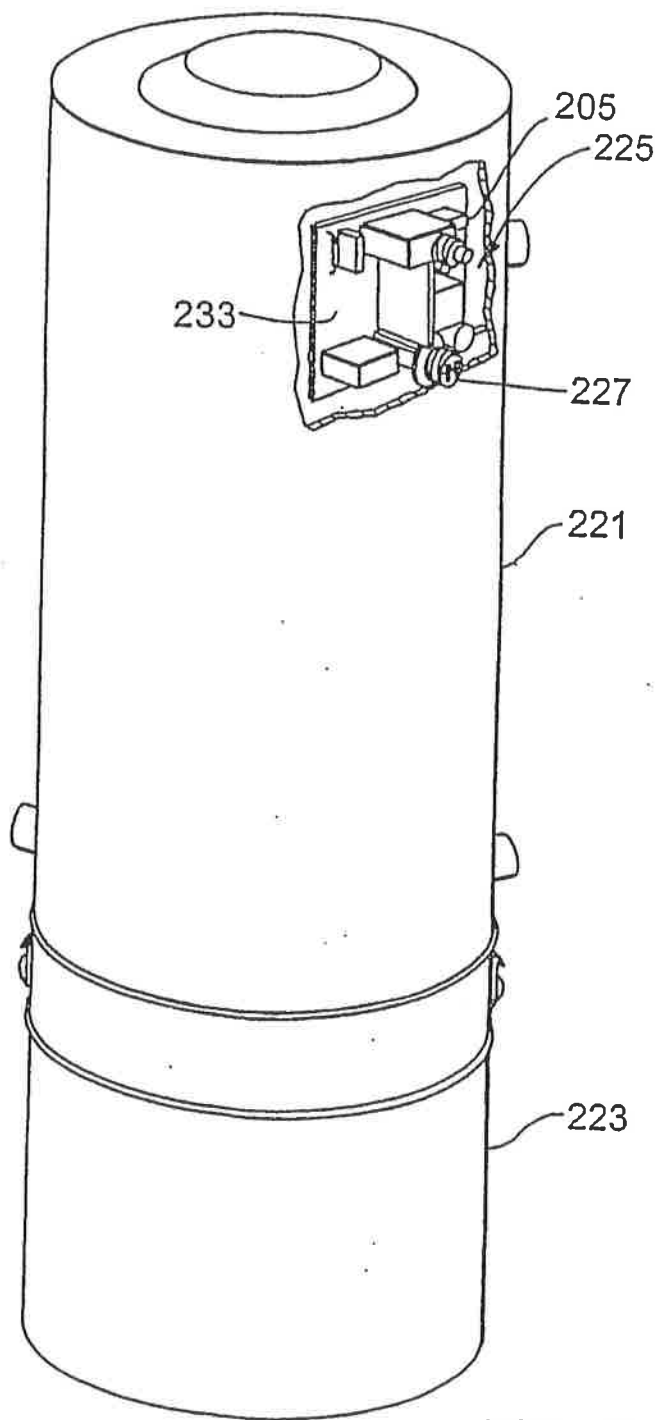

FIG. 16

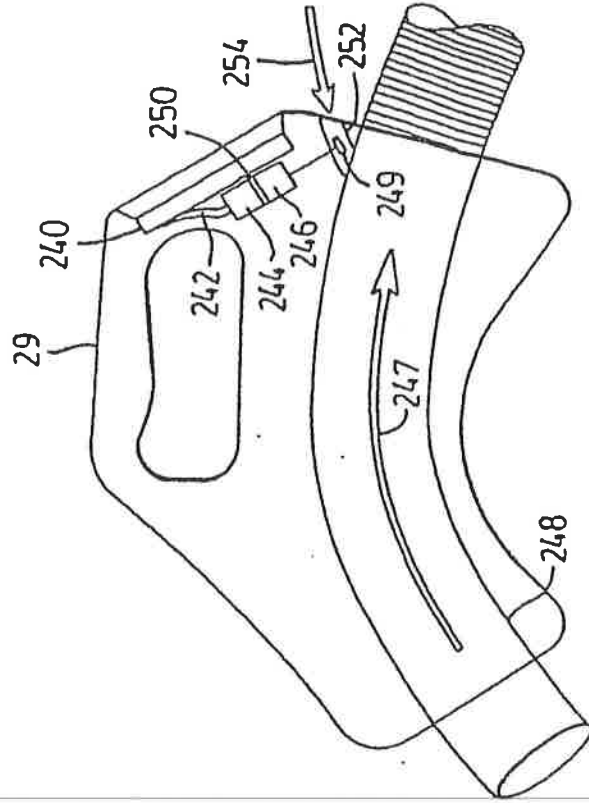

FIG. 17

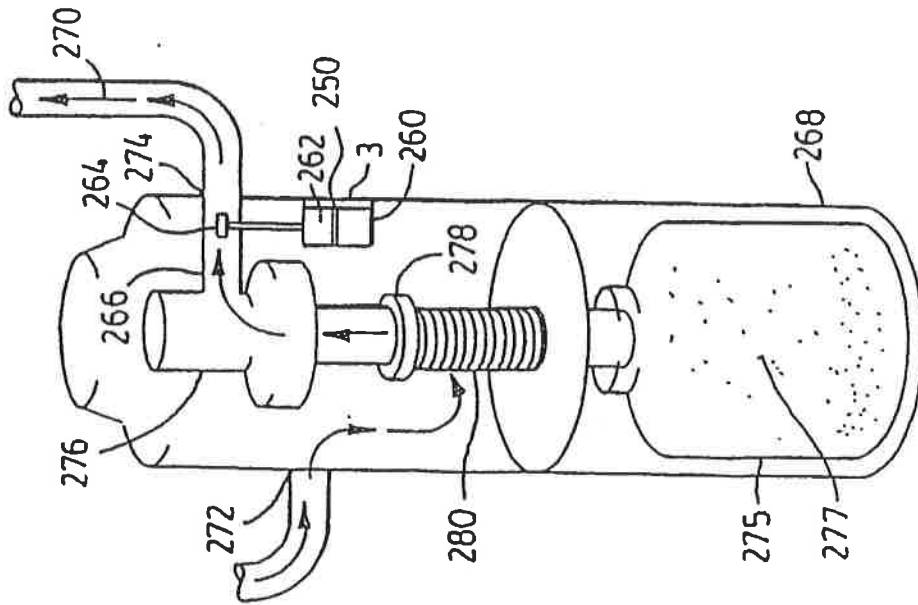

FIG. 18

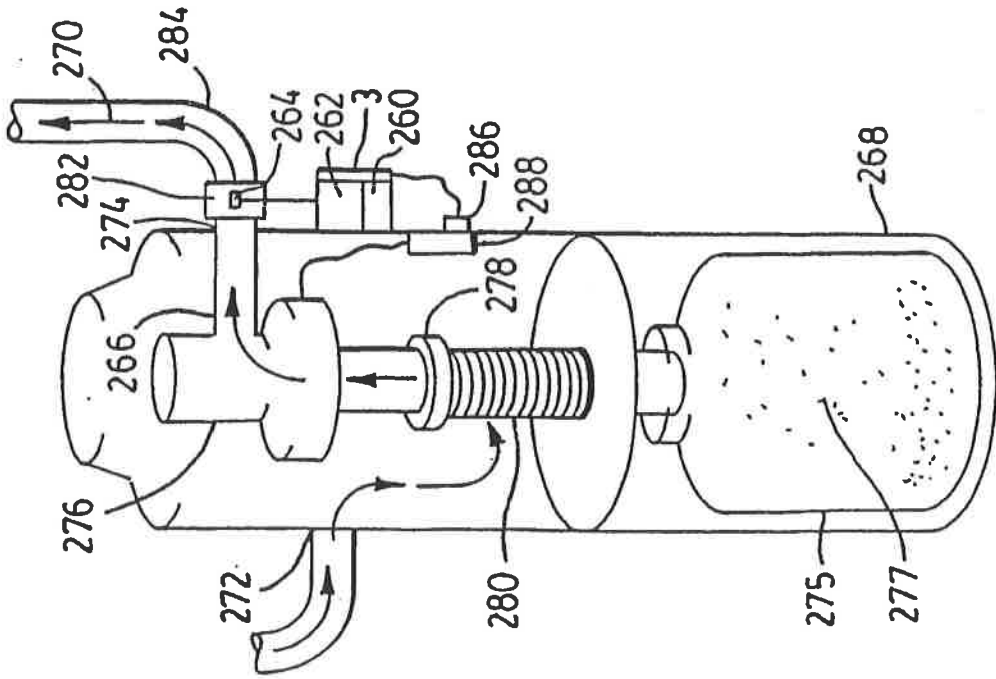

FIG. 19



FIG. 20

REFERENCES CITED IN THE DESCRIPTION

This list of references cited by the applicant is for the reader's convenience only. It does not form part of the European patent document. Even though great care has been taken in compiling the references, errors or omissions cannot be excluded and the EPO disclaims all liability in this regard.

Patent documents cited in the description

- JP 8117165 A [0007]
- JP 2003235767 A [0007]
- WO 03075733 A1 [0019]